

THE ORISSA MINERALS DEVELOPMENT COMPANY LIMITED

(A GOVT. OF INDIA ENTERPRISE)

Regd. Office

AG-104, Saurav Abasan, 2nd Floor
Sector – II, Salt Lake,
Kolkata-700 091
Tel.No.(033) 40169200 FAX No. (033) 40169267
[E-Mail - info.birdgroup@nic.in](mailto:info.birdgroup@nic.in)
[Web-site - www.birdgroup.gov.in](http://www.birdgroup.gov.in)

Mines Office:

P.O.Thakurani, Via-Barbil-758035
Dist-Keonjhar (Orissa)
Tel.No.06767-275218, 75379,276131
FAX No.06767-275530
[E-Mail - civilomdc@gmail.com](mailto:civilomdc@gmail.com)

**TENDER DOCUMENT
FOR
SUPPLY, INSTALLATION & COMMISSIONING
OF 01 (One) NO.
120 MT CAPACITY FULLY ELECTRONIC PIT LESS
TYPE
IN-MOTION RAIL WEIGHBRIDGE
AT
THAKURANI (TK-1) SIDING
ON
TURNKEY BASIS**

Tender Notice No.: OMD/Civil/02/2011-12

Dated: 12.07.2011

Name & Address of the Tenderer : _____
: _____
: _____

Money Receipt No.....

Dated.....2011

Cost of Tender Paper including VAT @ 4% Rs. 1040/- (Rupees one thousand forty) only

SIGNATURE OF ISSUING OFFICER

SIGNATURE OF THE TENDERER

THE ORISSA MINERALS DEVELOPMENT CO. LIMITED

(A GOVT. OF INDIA ENTERPRISE)

MINES OFFICE: P.O. – THAKURANI, VIA – BARBIL, DIST – KEONJHAR (ORISSA) 758035

REGD. OFFICE: AG-104, SAURAV ABASAN, 2nd FLOOR, SECTOR – II, SALT LAKE CITY, KOLKATA – 700091

TENDER NOTICE

Tender Notice No.: OMD/Civil/02/2011-12

Dated: 12.07.2011

Sealed tenders in prescribed format are invited only from the manufacturers/Dealers/Agencies of In Motion Rail Weighbridge of reputed RDSO & Railway approved make for supply, installation & commissioning of 01 (one) no. In-Motion Rail weighbridge of 120 MT capacity at Thakurani siding (TK-1). The tenderer must have valid license from weights & measure department.

1. Description of Job: Supply, installation & commissioning of 01 (one) no. In-Motion Rail weighbridge (Fully Electronic) of 120 MT capacity at Thakurani siding (TK-1).

2. Time of completion of work: Within 03 (Three) months from the date of issue of work order.

3. Availability of Tender document: The non-transferable tender documents can be obtained from The Manager (Finance), O. M. D. C. Ltd. Thakurani, Barbil, Dist-Keonjhar, Orissa on payment of Rs. 1040.00 (Rupees one thousand forty only) in cash on any working day up to 04.08.2011 during office hour.

Tender document shall also be available at web-site www.birdgroup.gov.in and it can be downloaded and used for submitting the offer. Separate demand draft towards cost of tender document as mentioned above shall have to be enclosed in addition to the earnest money, while submitting the tender; otherwise the tender will summarily be rejected.

4. Tender in prescribed format complete in all respects accompanied with earnest money of Rs. 50,000.00 (Rupees fifty thousand only) in the shape of Bank Draft/Pay order from any nationalized bank in favour of “**The Orissa Minerals Development Company Limited**” payable at Barbil should reach the office of The Manager (Finance), OMDC, Thakurani, Barbil, Dist-Keonjhar, Orissa on or before 05.08.2011 at 3.30 PM (IST) and the same will be opened on the same date at 4.00 PM (IST) in the presence of the tenderer or their accredited representatives.

5. Tenderers are advised to visit and familiarize themselves with the site conditions and concerned areas before submission of tender documents.

6. OMDC shall not be liable for any delay in submission of the tender documents and no extension to the date of tender submission and opening shall be given for this reason.

7. OMDC reserves the right to accept, reject, or split any part or in full of the tender without assigning any reason whatsoever, OMDC also reserves the right not to accept the lowest offer.
8. OMDC reserves the right to cancel the tender and in such case and event no claim of any tenderer for such a decision by the company shall be entertained.
9. The above descriptions of job are only indicative and the details given in the tender document.
10. The tender shall be valid for a period of four months (120 days) from the date of opening of the tender.
11. The expected date of commencement of work is 25.08.2011.

Asst. General Manager (I/C)

THE ORISSA MINERALS DEVELOPMENT CO. LIMITED

(A GOVT. OF INDIA ENTERPRISE)

MINES OFFICE: P.O. – THAKURANI, VIA – BARBIL, DIST – KEONJHAR (ORISSA) 758035

REGD. OFFICE: AG-104, SAURAV ABASAN, 2nd FLOOR, SECTOR – II, SALT LAKE CITY, KOLKATA – 700091

CHAPTER - I

INVITATION OF TENDER

1. Tenders in sealed covers in prescribed form and in conformity with the tender documents are invited only from the manufacturers/dealers/Agencies of In Motion Rail weigh bridge of reputed make for Supply, installation & commissioning of 01 (One) no. In-Motion Rail weighbridge (Fully Electronic) of 120 MT capacity at Thakurani siding (TK-1).

2. SCOPE OF WORK:

2.1. Preparation of complete layout drawings, plans & sections of all associated structures as per railways adapting norms/specifications & get approval from RDSO & Rail way Authority.

2.2. Design, manufacture & supply 01 (One) no. fully electronic pit less In-Motion Railway Weighbridge of 120 MT capacity along with Computer, printer, display unit and related accessories. Bill of quantity & specifications of In-motion weighbridge and other accessories to be provided with Techno-commercial bid.

2.3. Construction of RCC framed weigh cabin of 4mx4m inner size sealed against ingress of dust & moisture with suitable window, furniture, electrification etc. complete. It also includes the installation of 1.50 Ton capacity Air Conditioner (Split type), 1400 VA Inverter and lightening arrestor etc. as per detail bill of quantity and drawing enclosed. It also includes installation of lightening arrestor over the cabin.

2.4. Construction of base foundation by RCC work with supply of PSC sleeper 52 kg rail, RCC foundation slab required to be laid under Rail, construction of required earth pits, duct for cabling etc. complete

2.5. Cutting of track at weighbridge site with required tools and tackles, and to lay concrete sleepers, provide accessories like Pendrol clips, fish plates, ratchet holes, nuts & bolts.

2.6. Installation, commissioning, arrangement for wagon testing, approval from RDSO and railway's authorities, calibration, verification and stamping by Legal Metrology department (Weights & Measure), Govt. of Orissa and commissioning within the agreed cost and scheduled time. Agency has to maintain the weighbridge under the guarantee period.

2.7. The successful bidder may have to supply and install 01 (one) no. similar In-motion weighbridge at TK-2 Siding, Barbil with related accessories including civil construction work at same scope of work & cost subject to clearance given by Railway Authority.

3. SPECIFICIATIONS: -

a. Weighbridge-

Standard electronic, 120 MT, fully electronic pit less in motion Rail weighbridge duly approved by RDSO, Railways and Legal Metrology dept, Govt. of Orissa.

Provided with Surge Protection Device to safe guard the weigh Rail sensors and system electronic against high voltage, lightning surge. Over speed mast with lamps and hooter for visual and audio alarm, track switches, junction box, cables etc.

* Computer with all accessories of latest configuration of reputed make like Compaq/Lenovo/HP/HCL of Core –I3, RAM-2GBDDR-III, Hard Disk – 500GB & TFT Monitor 18.5" size

* DOT matrix Printer, 136 Column, 24 pin, 300 CPS with all accessories of reputed brand like Wipro/EPSON

* UPS, capacity 1.0 KVA of reputed brand

* To provide necessary software for online weighment for taking direct printout (for immediate printout, daily printout and monthly printout with storage of memory for at least three years).

b. Civil Work – Work should be carried out as per various codes of practices provided by BIS & CPWD Norms.

c. Electrical Work -- Work should be carried out as per IEI rules. All the electrical items as per BIS norms.

i. Split Air Conditioner (1.50 Ton), 5 star rating with stabilizer (4KVA, voltage range 110 to 300 volt) with suitable starter and make of Blue Star/ Voltas/Carrier.

ii. 1400 VA Inverter make Sukam / Micro-Tech / Luminous with battery (make of Excide/Micro-Tech Heavy Duty) & Inverter wiring of all light point and fan point all materials, labour, carriage etc. complete

4. QUALIFYING REQUIREMENTS:

In order to qualify in the techno commercial bid of the tender, the tenderer must produce the following documentary evidence with the techno-commercial bid.

4.1 In case of down loading, the cost of tender paper of Rs 1040/-(Rupees ten thousand forty only) including VAT @ 4% in shape of Demand Draft/Bankers Cheque/Pay order from nationalized/ Schedule Bank drawn in favour of **"The Orissa Mineral Development Company Limited"** payable at Barbil to be enclosed.

4.2 The EMD of Rs 50,000.00 (Rupees fifty thousand only) in shape of crossed Demand Draft/Bankers Cheque/ Pay order from nationalized/ Schedule Bank drawn in favour of **"The Orissa Mineral Development Company Limited"** payable at Barbil to be enclosed.

4.3 Sealed tender are invited only from Manufacturer/ Dealer/Agencies of In-Motion Rail Weighbridge of RDSO approved. The tenderer must have valid license from weights & measure department.

4.4 The agency must have experience of successful completion of at least one project of supply, installation and commissioning of Electronics In-motion pit less Weigh Bridge of 120TM Capacity on turnkey basis to their credit and must produce document in support of their credential.

Note- Experience in the name of the partners of the firm or that of Directors of the company will be considered as experience of the firm/company participating in the tender.

- 4.5 a) Registered Partnership deed in case of a partnership firm
b) Memorandum of Article and Article of Association in case of a Joint stock company,
c) Proprietorship certificate duly certified by a notary in a stamp paper in case of proprietorship firm is to be enclosed.
- 4.6 Copy of the Income Tax PAN and copy of income tax return for any one of the last three years i.e 2008-09, 2009-10 and 2010-11 signed by Chartered accountant is to be enclosed.
- 4.7 Copy of sale tax registration number/VAT registration number and up-to-date clearance certificates
- 4.8 The agency must have service tax registration Number. Copy of service tax number is to be enclosed.
- 4.9 The annual turn over of the bidder should not be less than 50.00 (fifty) Lakh. Photocopy of the balance sheet, TDS or any other documentary should be enclosed.
- 4.10 An under taking, in company /firm's letter head is required regarding that the party has not been debarred/blacklisted by any PSU and OMDC at any point of time.
- 4.11 A declaration to be submitted that the bidder has carefully read all terms and conditions of the tender document and he is fully satisfied and accepted all terms and condition of the tender as per undertaking format attached as per Annexure- I.
- 4.12 The tenderer before submission must sign each page of the tender schedule. Otherwise the tender will be treated as invalid.
(Note: Submission of any forge document will attract legal action including rejection of tender or cancellation of contract at the risk and cost of the contractor if awarded.)

5. SUBMISSION OF TENDER:

- 5.1. Non-transferable separate tender documents can be obtained from the office of the Manager (finance),The O. M. D. Co. LTD, Thakurani, Barbil, Dist-Keonjhar, Orissa during office hours on any working day as per schedules given below on payment of Rs 1,040.00 (Rupees one thousand forty) only. The tender document can also be downloaded from our website www.birdgroup.gov.in. In that case the cost of tender document is to be paid in form of demand draft drawn in favour of "**The Orissa Minerals Development Company Limited**" payable at Barbil along with T.C. bid.
- 5.2. Tender in prescribed format complete in all respects accompanied with the earnest money deposit of Rs. 50,000.00 (Rupees fifty thousand only) in the form of Bank draft/Pay order from any Nationalized bank/scheduled bank in favour of "**The Orissa Minerals Development Company Limited**" payable at Barbil should reach the office of the Manager (Finance), OMDC, Thakurani, Barbil, Dist-Keonjhar, Orissa on or before the scheduled date and time given below.
- 5.3. The O.M.D.CO.LTD shall not be liable for any delay in submission of the tender documents due to postal delay or any other reasons and no extension to the date of tender submission/tender opening shall be given for any reason.
- 5.4. The tender document shall be submitted in two parts i.e. part-1 Qualifying/Techno commercial bid and part-2 Price bid in separate sealed envelopes super scribing the respective words in both the envelopes. Both the envelopes should be kept in another envelope super-scribing the tender notice no and date. The EMD should be submitted along with the Techno commercial bid. The Techno commercial bid not accompanied with EMD is liable to be rejected. The EMD will not carry any interest.

- 5.5. The part-1 Techno-commercial bid shall be opened in the presence of the tenderer or their authorized representatives in the office of the Sr. Manager (Finance) of company's office at Thakurani on the scheduled date and time. The date of opening of part-2 price bid shall be intimated separately to the tenders whose Qualifying/Techno commercial bid would be found acceptable.

6. DETAILS ABOUT SITE:

The work site is located at Thakurani Siding (TK-1) is about 04 km away from Barbil town and its soil characteristics are semi-hard. All the construction materials are available in the Barbil market. The tenderer are advised to visit the site to acquaint themselves with the working conditions, soil, and Rail track to be handled etc. before submitting the tender document. The exact location of installation of new weighbridge shall be shown by the Sr. Manager (Project).

7. THE SCHEDULE

- 7.1 The contractor shall commence the above construction work within seven days from the date of issue of work order.
- 7.2 The entire work shall have to be completed within 03 (three) months from the date of issue of work order.
- 7.3 Last date of submission of offer 05.08.2011 up to 3.30 PM at Office of the Manager (Finance), Thakurani, Barbil, Dist – Keonjhar (Orissa).
- 7.4 Opening of the tender documents will be on 05.08.2011 at 4.00 PM in the Office of The Manager (Finance) in the presence of the tenderer or their authorized representatives.

>>>>>>>>>>

THE ORISSA MINERALS DEVELOPMENT CO. LIMITED

(A GOVT. OF INDIA ENTERPRISE)

MINES OFFICE: P.O. – THAKURANI, VIA – BARBIL, DIST – KEONJHAR (ORISSA) 758035
REGD. OFFICE: AG-104, SAURAV ABASAN, 2nd FLOOR, SECTOR – II, SALT LAKE CITY, KOLKATA – 700091

CHAPTER - II

GENERAL AND COMMERCIAL TERMS & CONDITIONS OF THE CONTRACTS

1. DEFINITIONS:

- a) **Tenderer/Bidder:** Tenderer/Bidder means a person, Society, Firm, or Company willing to participate by accepting terms and conditions given in the tender documents.
- b) **Tender:** Tender means the work to be perform according to the tender documents (both technical and commercial) submitted by the tenderer for consideration of OMDC.
- c) **Name of the Tender:** Name of the Tender means the work to be perform by the tenderer.
- d) **Techno-commercial Bid:** Techno-commercial Bid means documents regarding eligibility condition as stipulated in the tender documents for qualifying the bidder for consideration of the Price Bid
- e) **Scheduled Rate:** Scheduled Rate means the rate quoted by the tenderer in the prescribed format for various activities to be performed by the tenderer.
- f) **Price Bid:** Price Bid means the document containing the scheduled rate to be considered for the purpose of evaluation and award of contract.
- g) **Contractor/Consultant/Agency:** Contractor means the person or society, firm, company whose tender has been accepted by the OMDC.
- h) **OMDC:** OMDC means "The Orissa Mineral Development Company Limited". A company incorporated in India and having its registered office at AG-104, SAURAV ABASAN, 2nd FLOOR, SECTOR – II, SALT LAKE CITY, KOLKATA – 700091
- i) **Employer:** Employer means OMDC Ltd.
- j) **Competent Authority:** Competent Authority means CMD or any designated officer by the CMD.
- k) **Taxes:** Taxes means Income Tax, Surcharge, Service Tax, Cess Tax, value Added Tax, Entry Tax, and any Other Tax, Levy, Fees, Cess imposed by the Government from Time to Time.

2. EARNEST MONEY:

- 2.1. Cheques, Bonds, guarantee bonds and Govt Securities (Stock Certificates, bearer bonds, promissory notes, and cash certificates) will not be accepted towards the earnest money. No interest will be paid on EMD.
- 2.2. Tender without prescribed earnest money shall be rejected.
- 2.3. Earnest money shall be refunded to the unsuccessful bidders after the finalization of the tender.
- 2.4 In case of tenderer/successful bidder fails to take up the work within 15 days from the date of award of L.O.I./Work Order or fails to cope up with the progress of work for any reason whatsoever, OMDC reserves the right to terminate the contract and forfeit the earnest money/security deposit of the successful bidder and the cost of the work he/they have done by that time and the work may be rescinded.

3. PERFORMANCE GUARANTEE:

Performance Guarantee required to be submitted by the successful bidder only. The amount of performance guarantee shall 5% of the total value of the contract and which is deposited by successful bidder at a time of execution of agreement. The EMD deposited by successful bidder along with technical bid shall be adjusted with performance Guarantee. The Performance Guarantee (P.G.) will be refund with security deposit.

4. SECURITY DEPOSIT (SD):

5% of total contract price as prorata to be deducted from every progressive bill towards security deposit. The security deposit will be returned after 12 months (one year) from completion of the job in all respect and successful handover of the said work and clearance certificates from commercial department of the company. The security deposit will bear no interest.

5. LIQUIDATED DAMAGE FOR DELAY IN COMPLETION OF WORK:

If the contractor fails to successfully complete the work as per the specification within the time period mentioned in the work order, the contractor shall pay as a liquidated damage a sum of equal to half percent of contract price per week delay. The total amount of liquidated damage for delay under contract will be subject to a maximum of 10% of contract price. No Liquidated damage is applicable if the completion period of the work gets extended beyond the stipulated period of the contract due to no fault of the contractor. The contractor should address the sufficient justification for time extension and a committee consisting of official will examine and recommended for approval of competent authority.

6. TERMINATION OF CONTRACT:

OMDC reserves the right to terminate the contract either in part or in full due to reasons for delay in completion, bad working or any other abnormalities noticed during construction work. OMDC shall in such event give seven days notice in writing to the contractor of his decision to do so.

7. RISK PURCHASE:

In the event of failure to fulfil the contract terms and execution of work as per letter of contract/work order the OMDC reserves the right to make the contractual obligation carried out by alternative arrangements and OMDC shall recover from the contractor any additional cost involve therein.

8. CHANGE OF QUANTITY:

OMDC reserves the right to vary the quantity of item or group of items to be specified in the specification for which unit price will remains unchanged.

9. INSURANCE:

The contractor shall do all necessary insurance till job is handed over.

10. PRICE ESCALATION:

No price escalation will be allowed by OMDC at any time for whatsoever the reason.

11. THE PRICE QUOTED:

The tenderer shall quote his price which should include all Taxes, royalties, duties and all other levies applicable i.e. sales Tax, Income Tax, Custom duty, Contract Tax, Entry Tax and Service Tax etc. No extra cost will be entertained on account of any Taxes and duties. The quoted price should be inclusive of all freight, insurance and incidental charges towards stamping of weighbridge. The test van required for testing and calibration to be arranged by bidder.

12. MEASUREMENT:

12.1 The quantities set out in the Scheduled of items are the estimated quantities of the works but they are not to be taken as the actual & correct quantities of the works to be executed by the contractors in fulfilment of his obligation under the contract.

12.2 The Engineer shall expect as otherwise stated ascertain & determine by measurement the value of work done in accordance with the contract. He shall when he required any part or parts of the works to be measured give notice to the contractor who shall forthwith attend or send a qualified agent to assist the Engineer or the Engineer's representative in seeking such measurement & shall furnish all particulars required by either of them. Should the contractor not attend or neglect or omit to send such agent then the measurement made by the Engineer or approved by him shall be taken to be correct measurement of the works.

13. SUBMISSION OF BILLS:

Bills shall be submitted after completion of the job in the office of Manager (Finance), OMDC, Thakurani, Barbil, Dist- Keonjhar, Orissa in triplicate duly certified by commercial department and Civil Department. Deductions as per terms and conditions of the work order and statutory requirements shall be made.

14. PAYMENT CONDITIONS:

Depending on the progress of the work and written request of the contractor, R.A. Bill will be paid. Running account Bill, if payable as per contract will be submitted by contractor, these will be verified by the Sr. Manager (Project) and

commercial department through the quality and volume of the work executed and 90% of work done value will be paid as running account bill. Bill of the work executed shall be jointly signed by the Engineers of the company and the Contractor. The final payment will be made on completion of all the work and fulfilment of contractor liabilities.

15. PROVIDENT FUND AND OTHER STATUTES UNDER LABOUR LAWS:

The contractor shall be fully responsible to comply with all his statutory obligations as employer including all contributions under P.F. and Pension Scheme (EPF) etc. under the employees (EDLI), Employees' State Insurance Act, 1952, Employees' Deposit Linked Benefit Act, 1961, etc., and all other such obligations/liabilities in respect of their labour engaged by them for the job undertaken under the contract as per applicable statutory provisions / law and Government notifications, and will take full liability on this account. The company will not take any financial liability on this account. In the event of failure of the contractor to comply with the above, the company shall be enlisted to recover the amount by deduction from any amount payable to the contractor under the contract, including security deposit, or as dept payable by the contractor.

16. GUARANTEE:

1. Guarantees whenever required by the contract shall be furnished by the contractor to the OMDC Ltd. On forms approved by the engineer and shall signed by both the contractor and the sub-contractor's work is involved.
2. The contract assumes a proper degree of skill on the part of the contractor and all his workmen employed. The contractor shall consult with engineer whenever in his judgement a variation in the work of construction or in the quality of the materials specified would be beneficial or necessary to fulfil the guarantees called for in the contract. Such variations shall be carried out by the contractor only when authorized by the engineer in writing. The request for such changes shall be made before the contract agreement is executed otherwise guarantees will be understood to hold good for work as specified in the contract and any variation necessary to fulfil such guarantees shall be carried out by the contractors at his own cost.
3. The guarantee period for all the equipments/accessories of In-Motion Weighbridge including Computer, Printer, Digitizer, UPS, Air Conditioner and Inverter etc. should not be less than 01(one) year from the date commissioning and stamping. All the documents related with Warrantee / Guarantee to be submitted to the OMDC Ltd.
4. A performance guarantee in approved form shall be furnished by the contractor to the owner for the due observance, fulfilment and performance by the contractor of the terms and conditions of the contract.

17. MAINTENANCE OF DEFECTS:

If any defect is detected by the concern authority, the contractors shall make rectification of such defects during the maintenance period of twelve months (one year) from the date of completion of work. All such work shall be carried out by the contractors at his own expenses.

If the contractor shall fail to do any such work, the OMDC Ltd. shall be entitled to carry out such work by own workmen or by other contractors and the cost thereof deducted from contractor security deposit.

18. ANNUAL MAINTENANCE CONTRACT (AMC):

The Contractor should maintain all the equipments supplied related to the In-Motion weighbridge free of cost in quarterly basis for the period of 01 (One) year from date of commissioning and stamping of In-Motion Weighbridge. The contractor have to replace of any defective equipment by free of cost during AMC period.

19. EXPECTATION FROM THE TENDERER:

Tenderers, along with tender, shall submit the following documents duly attested by a Gazetted Officer/Notary Public.

Details and documents regarding financial status of the firm like latest Profit and Loss account, Balance Sheet, Auditor's Report etc. for last three completed years along with Banker's Certificate regarding financial stability to undertake the tendered work. Banker's Certificate should be specific and clearly outlining the limits of overdrafts. Bank Guarantees etc. being enjoyed by the Tenderers. The tenderer must submit specifications of their product with the techno-commercial bid.

20. AWARD OF CONTRACT

20.1. The company reserves the right to accept or reject any or all tenders or distributes the work amongst different tenderers without assigning any reason thereof.

20.2. Award of contract shall be made at the absolute discretion of OMDC. The company reserves the right to reject any part or whole of the tender without assigning any reason whatsoever. For such cancellation the tenderer shall not be entitled to claim any cost, charges, expenses incidental to or incurred by him through or in connection with the preparation and submission without assigning any reason whatsoever.

20.3 OMDC also reserves the right not to accept the lowest offer and to divide the work to more than one party/parties.

20.4 OMDC shall not be liable for any delay in receipt of the tender document by the Tenderers due to postal delay and no extension of time to the date of tender opening shall be given for this reason.

21. SIGNING OF AGREEMENT AND EXECUTION OF WORK:

21.1 The successful bidder is expected to appear in the office of Asst. General Manager (I/C) to sign the contract agreement within 5 days and start the work within 10 days from the date of issuance of LOI. In case the tenderer is decline to sign the agreement or to take up the work within stipulated time, in such eventuality will have any such claim.

21.2. In case the tenderer declines to take up the work, OMDC reserves the right to terminate the contract and forfeit the earnest money/security deposit of the contractors in such eventually, the tenderer have no claim for the cost he/they might have incurred for taking the work and the cost of the work he/they have done by that time and the work may be rescinded.

22. OBLIGATION OF THE CONTRACTOR:

The contractor shall be solely responsible for deductions and maintenance of record regarding Provident Fund, Pension Scheme, Deposit Link Insurance Fund in respect of contractors/employees employed by him in connection with the work mentioned in the description of work of this contract documents as required under Employees Provident Fund and Miscellaneous Provisions Act, 1952 and

Rules and Regulations made there under. The contributions to Provident Fund at the prescribed rate along with other contributions and charges have to be duly made as provided for in the said Act. The said contributions (both employer's and employees) along with other charges shall be deposited within the prescribed time to the Regional Provident Fund Commissioner. In case the contractor fails to comply with the above, the company reserves the right to arrange for the same and the entire amount shall be recovered from the bills/security deposit of the contractor(s) or otherwise.

23. RESPONSIBILITIES OF THE TENDERER/AGENCY/CONTRACTOR:

- 23.1 The work order is to be accepted by the tenderer within 3 days of communication of the same.
- 23.2 The tenderer will commence and complete the work as stipulated in the tender document
- 23.3 The agency shall have to make his own arrangements for traveling, boarding, lodging etc to the site including visit to the respective offices of Legal Metrology and others etc.
- 23.4 All the corrections/ compliances on deficiency pointed out by the Railway/ Government authorities during the preparation of the project should be duly complied by the contractor within the stipulated time.
- 23.5 The liaison required for the purpose should be exclusively done by the Tenderer/agency.
- 23.6 All other Expenditure incidental to such processing to be borne by the agency including statutory payments.
- 23.7 Preparation of drawings/plans and design, sections in digitized form. All soft copies in respect of preparation of above scope should be submitted to the OMDC. Two hard copy of the drawings shall be submitted to the Sr. Manager (Project).
- 23.8 The job cannot be sublet in part or in whole without the written consent of the Assistant General Manager (I/C) OMDC, Thakurani.
- 23.9 You will comply the direction of Assistant General Manager (I/C)/ Sr. Manager (Project) or his authorized representative from time to time.
- 23.10 All security arrangement for the materials to be utilized in the project shall be done by the contractor up to commissioning and handing over the weighbridges.

24. SHORT CLOSURE NOTICE:

In case of short closure of the contract either party will give 30 days notice in writing. In case of failure to do so the loss suffered by the company will be borned by the agency.

25. FORCE MAJEURE CLAUSE:

Time being the most important feature of the contract if either party is prevented from the performance of its obligations in whole or in part for reasons of force majeure viz acts of God, acts of Government, acts of public

enemy, war, hostility, civil commotion, sabotages, fire, floods, explosions, epidemics, lawful strikes, lockouts or statutory action or any cause of whatever nature or description beyond the control then provide notice of happenings of any such eventuality is given by the affected party to the other party within 15 days from the date of occurrence and cessation of the force majeure the period of force majeure shall be excluded from the time specified for fulfilment of obligations of the party prevented by force majeure. If any of the events specified in this clause lasts for a continuous period of less than 7 days, such events shall not be construed to be force majeure events. Neither part can claim any compensation from the other party because of force majeure events.

26. DEPUTATION OF EXPERIENCE REPRESENTATIVE DURING CONSTRUCTION & INSTALLATION:

The successful tenderer shall depute an authorized experience representative to carry out the turnkey job as per the work order and report to Sr. Manager (Project). The successful tenderer must submit all detail drawing and as well as specification before carrying out the job.

27. STAMPING AND VERIFICATION:

The weighbridge has to be stamped and verified by Railway Authority & Legal Metrology department of Govt. of Orissa. The successful tenderer shall arrange test wagon and present the weighbridge to the weight and measure department for necessary stamping and verification. Necessary stamping fee shall also be deposited by the Company (OMDC).

28. VALIDITY OF TENDER:

The tender shall be valid for a period of four months (120 days) from the date of opening of the tender.

29. OTHER CONDITIONS:

- 29.1 The rate quoted in the tender should be in word and figure and unit in words for price.
- 29.2 The contractor will supply all the materials, labours, tools and implements required for above construction.
- 29.3 Income Tax & Sales Tax will be deducted as per respective Acts.
- 29.4 All legal liabilities/ statutory payments connected with the above work should be borne by the contractor.
- 29.5 All statutory requirements to be maintained by contractor as applicable for the working in the mines.
- 29.6 The contractor strictly in accordance with the specifications and work order should execute the work.
- 29.7 In case the material or work is not up to the specification, the management reserves the right to terminate the contract or deduct the cost thereof.
- 29.8 The payment will be made after measurement of the work on its completion by the civil department of OMDC.
- 29.9 The material to be supplied by the contractor shall be as per IS specification. All the Materials needed for the work must be approved by the Engineer and brought to the site in bulk.

- 29.10 If any work either in temporary or permanent nature or necessary to complete the work in all respect but not mentioned in the tender shall have to be done without extra cost.
- 29.11 The contractor will comply the provision of Mines Act 1952, payment of Wages Act, payment of Bonus Act & Rule & regulations made there under.
- 29.12 The contractor shall take licence under the contract labour (Regulation & Abolition) Act 1970, if required under said Act.
- 29.13 The contractor has to arrange the adequate lighting arrangement for the work wherever necessary at his own cost.
- 29.14 After the work is finalized, all surplus materials should be removed from the site of work. Preliminary such as vats, mixing platform etc. should be dismantle and all materials removed from the site and premises left neat and clean.
- 29.15 No payment will be made for bench marks, level pillars profile and benching and leveling the ground where required.
- 29.16 The Engineer will have right to inspect the scaffolding, centering and shuttering made for the work and reject partly or fully such structures if found defective in their opinion.
- 29.17 The contractor is required to pay royalty to the Govt. of minor mineral like sand, metal, chips, boulder and moorum as fix from time to time and produce such as documents to the company, failing which amount towards royalty of different materials as utilize by them will be recovered from their bills and deposited in the revenue of concerned department.
- 29.18 If site Engineer/ Engineer in-charge wants to conduct any test related to the job, the testing charges including expenditure the collection of samples specimen etc. will be born by contractor.
- 29.19 The successful tenderer shall depute an authorized technical representative to supervise and guide the construction work/electrical work on day to day basis and report to Sr. Manager (Project) and Dy. Manager (Electrical).

30.0 ARBITRATION

Any dispute or difference under or arising out of in respect of the Agreement/Accepted Contract may be referred to the sole Arbitration of a person appointed by The Chairman cum Managing Director, The Orissa Minerals Development Company Limited, AG-104, SAURAV ABASAN, 2nd FLOOR, SECTOR – II, SALT LAKE CITY, KOLKATA – 700091 & his decision in the matter will be final & binding on the contractor & the company. The arbitration shall be carried out as per Arbitration Act. 1996 & rules made there under as amended from time to time.

Sr. Manager (Project)

THE ORISSA MINERALS DEVELOPMENT CO. LIMITED

(A GOVT. OF INDIA ENTERPRISE)

MINES OFFICE: P.O. – THAKURANI, VIA – BARBIL, DIST – KEONJHAR (ORISSA) 758035

REGD. OFFICE: AG-104, SAURAV ABASAN, 2nd FLOOR, SECTOR – II, SALT LAKE CITY, KOLKATA – 700091

CHAPTER – III

INSTRUCTION TO TENDERERS

1. Tender must be submitted in sealed envelope marking the name of work as mentioned in the tender notice and addressed to The Orissa Minerals Development Company Limited, At/P.O-Thakurani,Via-Barbil-758035, Dist-Keonjhar, Orissa on or before the time mentioned in the tender notice. The Tenders will be opened soon after on the same day and rates read out in presence of the Tenderes or other representatives as are present.
2. Tenders sealed and super scribed as above may also be sent by hand only. A tender which is received after the time and date specified above, is liable to rejection. Company is not responsible for any loss of Tender or late receipt of tenders.
3. Any tender delivered or sent otherwise will be at the risk of the Tenderers.
4. Tender form containing 'over written' or 'erased' rate or rates and amount not shown in figures and words in English will be liable to rejection.
5. Tender quoting rates on until different from those prescribed in the tender schedules will be liable to rejection. Tenders not received in the prescribed from as specified therein and without earnest money at the time of opening will be summarily rejected.
6. If a Tenderer seeks to clarify his quotations or rates, this should only be done in a separate covering letter No. material modifications to the specifications, item description, contract clauses etc. will however, be entertained. Other clarifications may be considered. If the contents of the covering letter are to be considered, as part of the quotation, this should be specifically mentioned by the tenderer, it any of these conditions admitted for consideration has a financial bearing on the cost quoted, and the additional cost arising out of this condition will be added for comparative evaluation of tenders.
7. Any tender containing clerical or arithmetical mistakes may be rejected.
8. Any request from the Tenderer in respect of additions alterations, modifications, etc of either terms or conditions or rates of his tender after opening of the tender may lead to rejection of his tender. If the Tenderer, with draws his tender after opening of the tender but before the expiry of the validity period of the tender. The earnest money shall be liable to be forfeited.
9. The successful tenderer shall make his own arrangement for all materials except as specified in the contract (if any)

10. By submitting a tender for the work a Tender will be deemed to have satisfied himself by actual inspection of the site and locality of the work, that rates quoted by him in the Tender will be adequate to complete such work according to the specifications and condition attached thereto and he has taken into account all condition and difficulties that may be encountered during its process and to have quoted labour and material rates which shall include cost of material with taxes, Outcry ,land other duties, lead, lift, loading and unloading freight for materials and all other charges necessary for the completion of the work, to the entire satisfaction of the engineer.
11. Tenderers must also submit with the Tender copies of testimonials with regarded to their experience and satisfy The O.M. D. Co. Ltd.'s authorities on the following points if and when called upon to do so.
 - (i) His position as an independent contractor or as the properly accredited agent of a responsible firm, in proof of which he must produce the requisite registered Power of Attorney and the expressed authority from the same firm to act as its agent.
 - (ii) His ability, to supervise his work personally or in the event of ill-health or authorised absence there from to employ a competent and responsible agent who is to be specially named and approved beforehand.
12. The following particulars must also accompany the tender.
 - (a) Details of works of similar type and magnitude carried out by the Tenderer. In the proforma shown in Appendix-I.
 - (b) Details of constructions Plants and Equipment available with the tenderer, for use in this work in the proforma shown in Appendix-II.
13. Acceptance of the Tender will be intimated to the successful Tenderer through a letter of intent. The contractor shall than be required to execute an agreement within the time specified in the letter of intent. In the event of failure on the part of Contractor to sign the agreement within the specified time the amount of earnest money shall be forfeited and the acceptance of his tender shall be considered as withdrawn.
14. If the Tenderer has a relative employed in any capacity in The O.M.D. Co. Ltd. shall inform the authority calling for tenders of the fact when submitted his tender, failing which his contract may be rescinded, if the fact subsequently comes to light, and he shall be liable to make good to the employer any loss to damage resulting from such cancellation to the like extent provided in the case of cancellation under clause 15.2 of general condition of contract.
15. No contract work, however petty, may be carried out except under and in accordance with a duly executed agreement or a special written authority from a duly authorized office of the employer.
16. No agreement is valid unless signed by the contractor or his duly authorized agent and by a competent person on behalf of the employer.
17. Canvassing in any form is strictly prohibited and the tenders submitted by the Tenderers, who resort to canvassing, will be liable to rejection.

18. The form of agreement, form of Tender, invitation of tender, Instruction to Tenderers, General conditions of contract special conditions of contract specifications, Drawings and the rates and amount quoted against the items of the tender schedule together with letter of intent awarding the works shall form the contract, if there be any difference between the description in the specifications and drawing and the works items in the tender schedule, the works in the tender schedule shall prevail for determining the rate.
19. In case of abnormality low quoted rate, the company reserves the right to call justification lowest tenderer. Further the contractor may have to submit an amount fixed by the company before of work in the form of Bank Guarantee/Demand Draft against performance guarantee.
20. The successful bidder may have to supply and install 01 (one) no. similar In-motion weighbridge at TK-2 Siding, Barbil with related accessories including civil construction work at same scope of work & cost subject to clearance given by Railway Authority.

Date.....

For: The Orissa Minerals Dev. Co. Limited.

THE ORISSA MINERALS DEVELOPMENT CO. LIMITED
(A GOVT. OF INDIA ENTERPRISE)

PART-1

TECHNO-COMMERCIAL BID

Sub: Supply, installation & commissioning of 01 (one) no. In-Motion Rail weighbridge (Fully Electronic) of 120 MT capacity at Thakurani siding (TK-1).

The tender shall fill in this questionnaire and submit with his offer. The information is required in this form to facilitate tender processing and better understanding. Some of the information also required for the engineering facilities connected with the work.

The tender paper without completely filled in the questionnaire shall be considered incomplete and may be liable for rejection.

THE ORISSA MINERALS DEVELOPMENT CO. LIMITED PART-1- TECHNO COMMERCIAL BID		
SL NO	PARTICULARS	INFORMATION BY BIDDER
01	Name of the bidder	
02	Address of the bidder	
03	Phone number	
04	Mobile number	
05	FAX number	
06	Cost of tender paper paid (In case of down loading of the tender paper, whether the agency has enclosed cost of tender paper of Rs 1040/-(One thousand forty rupees) in shape of DD in favour of "The Orissa Mineral Development Company Limited". payable at Barbil.	MR/BC/DD NO: Date: Drawn on: Amount:
07	Whether the agency has enclosed EMD of Rs 50,000.00 (Rupees fifty thousand only) in shape of crossed DD in favour of "The Orissa Mineral Development Company Limited" payable at Barbil.	MR/BC/DD NO: Date: Drawn on: Amount:
08	Whether Documentary evidences are enclosed by bidder as a Manufacturer / Dealer / Agency of RDSO approved In-Motion Rail weighbridge.	

09	Whether Documentary evidence is enclosed by bidder in support of valid license from Weights & Measure Department.	
10	Status of the bidder [sole proprietorship/Partnership/company-private limited or Public limited]The tenderer shall enclose Affidavit from a Notary in a stamp paper in case of sole proprietorship / Partnership deed incase of Partnership firm/MOA & AOA incase of company, as applicable)	
11	Whether experience certificate is enclosed (Work order/supply order must be enclosed)	
12	Whether the bidder is an employee or any relative is working in OMDC. Please mention the name, designation & department of self or such relative.	
13	Whether the agency has submitted copy of PAN and copy of income tax return for any one of the last three years i.e 2008-09, 2009-10 and 2010-11. PAN Number is to be mentioned.	
14	Whether the agency has service tax registration Number. Copy to be enclosed. Service tax no. is to be mentioned.	
15	Whether the tenderer is a Manufacturer/Dealer/Agent of In Motion Railway weighbridge 120 ton capacity of reputed make (Name of the make, specifications & address should be enclosed. Proof of Manufacturer/ Dealer/Agent is to be enclosed.	
16	Whether the agency has got experience of successful completion of at least one project to their credit. Document in support of their credential to be enclosed.	
17	Whether photo copy up-to-date Sales tax clearance certificate attached	
18	Whether photo copy of PF registration no. attached, if any. PF registration number is to be mentioned.	
19	Whether any documentary evidence of turn over of the bidder not less than 50.00 Lakhs in a single financial year	

	during last three financial year attached. TDS certificate, B/S & P/L account is to be enclosed.	
20	Whether all relevant drawing and design of in-motion weighbridge 120 ton capacity & other ancillary jobs to be enclosed.	
21	Any deviation from Tender documents.	
22	Whether an under taking, in company /firm's letter head is required regarding that the party has not been debarred/blacklisted by any PSU and OMDC at any point of time.	
23	Whether a declaration to be submitted that the bidder has carefully read all terms and conditions of the tender document and he is fully satisfied and accepted all terms and condition of the tender as per undertaking format attached as per Annexure- I.	
24	Whether the tenderer before submission must sign each page of the tender schedule. Otherwise the tender will be treated as invalid.	
25	Whether list of construction plants & equipments (Enclosed in separate sheet)	
26	Whether details of Air conditioner to be mentioned (Name, Make, Model, Capacity) (Enclosed in separate sheet)	
27	Whether details of Computer & inverter is to be mentioned (Name, Make, Model, Capacity) (Enclosed in separate sheet)	

CERTIFICATES TO BE GIVEN BY THE TENDERER:

In response to the tender invited by you vide tender notice no Ref No: OMD/Civil/02/2011-12 dated: 12.07.2011, I/We examined the terms and conditions of the tender document of the contract. I/We agree to abide by all instructions in these documents attached here to and hereby bind myself/ourselves to execute the work as per schedule stipulated in the Tender Notice. Certified that above mentioned particulars are correct and true to the best of my/our knowledge. In case any statement made above is found not correct my/our tender may be rejected by OMDC Ltd. I/we also certify that I/We have visited the site and got myself/ourselves acquainted with local conditions. My/Our price bid is based on the basis of our full understanding about the job. My/our price bid is based on our full understanding about the job. It is to confirm that our offer shall be valid for 120 days from the date of opening of the techno commercial bid. I/We also authorize the company to forfeit my earnest money and security deposit in case I/We fail to execute the job if my/our tender is accepted.

SIGNATURE OF THE TENDERER WITH SEAL

THE ORISSA MINERALS DEVELOPMENT CO. LIMITED

(A GOVT. OF INDIA ENTERPRISE)

APPENDIX-I

Tenderers must fill in the under-noted column:

Sl. No	Full particulars of installation & commissioning of In-Motion Rail Weighbridge on Turnkey basis by the tenderer	Amount of work	Schedule Completion time given by authority	Actual completion time	Name & address of authorities for whom work was carried out.
--------	---	----------------	---	------------------------	--

1. Work executed in the name of Tenderer.

2. Work executed by the Tenderer not in the name of Tenderer but in a different name or in a different partnership.

N.B: A separate sheet may, if required, be used for giving the details in the proforma mentioned above. The sheet shall be duly signed and stitched to the tender.

THE ORISSA MINERALS DEVELOPMENT CO. LIMITED

(A GOVT. OF INDIA ENTERPRISE)

APPENDIX - II

Scheduled for installation and commissioning of In-Motion weighbridge.

SI No.	Description of job	Details	Approximate time is to be required	Remarks
--------	--------------------	---------	---------------------------------------	---------

N. B: A separate sheet may, if required, be used for giving the details in the proforma mentioned above. The sheet shall be duly signed and stitched to the tender.

THE ORISSA MINERALS DEVELOPMENT CO. LIMITED

(A GOVT. OF INDIA ENTERPRISE)

PART-2

PRICE BID

Bill of quantity for supply, installation and commissioning of 120MT pit less Railway In-Motion Weighbridge and construction of weigh cabin (4mx4m) inner size with electrification etc. complete at Thakurani Sading (TK-1).

Sl. No.	Description of job	unit	Quantity	Rate	Amount
				in Rs./ unit	in Rs./ unit
A	Supply, installation and commissioning of 120MT pit less Railway In-Motion Weighbridge				
	Design, manufacture, supply, installation, commissioning, testing & calibration etc. complete of 01 no. pit less In-Motion weighbridge of 120MT capacity with all accessories like Computer, UPS, Printer, Display unit etc. as per scope of work and specification given in the tender document.	Lot	01		
B	Supply and construction of base foundation and laying of PSC sleeper over the base foundation as per norms of RDSO. The detail bill of quantity is as follows.				
1	Earth work in excavation of foundation of drains in all sorts of soil including removing, spreading or stacking the spoils as directed. The item includes necessary trimming the sides of trenches, levelling, dressing and ramming the bottom, bailing out water etc., as required complete, including cost of shorting.	M ³	16.50		
2	Filling in foundation or plinth with local sand in layers not exceeding 150mm as directed and consolidating same by through saturation with water ramming complete including the cost of supply of sandall materials, labours, T&P, curing etc. complete	M ³	5.50		
3	Cement concrete in foundation with graded stone metal in 1:3:6 with 40mm stone metal all materials, labours, T&P, curing etc. complete	M ³	5.50		
4	Cement concrete 1:1.5:3 with graded stone chips (20mm down) excluding shuttering and reinforcement including all good quality approved materials mixed at site as per direction of engineer-in-charge (strength of concrete not less than M20) all materials, labours, T&P, curing etc. complete	M ³	11.00		

5	Reinforcement of tar steel grade Fe415 confirming IS 1786:1979 for reinforced concrete work in all sorts of structure including distributions bars, stirrups, binders etc. including initial straightening and removal of loose rust (if necessary) cutting of requisite length, hooking and bending to correct shape, placing in proper position and biding with 16 gauge black annealed wire at every intersection all materials, labours, T&P, etc. complete	qntl	6.00		
6	Hire and labour charges for shuttering and centering and necessary staging using approved stout props and thick hard wood planks of approved thickness with required bracing for concrete slabs, beams columns, lintels, curved or straight including fitting, fixing and striking out after completion of work with plywood shuttering of approved thickness or steel shuttering all materials, labours, T&P, etc. complete	M ²	10.00		
7	Supply of PSC Sleeper for 52 kg rail including accessories like pendrol Clip, metal liner, grooved rubber pad etc. complete.	Nos.	100		
C	Construction of 01 (one) no. weigh cabin (4mx4m) inner size for installation of in-motion weighbridge				
1	Earth work in excavation of foundation of drains in all sorts of soil including removing, spreading or stacking the spoils as directed. The item includes necessary trimming the sides of trenches, levelling, dressing and ramming the bottom, bailing out water etc., as required complete, including cost of shorting.	M ³	8.50		
2	Filling in foundation or plinth with local sand in leyers not exceeding 150mm as directed and consolidating same by through saturation with water ramming complete including the cost of supply of sandall materials, labours, T&P, curing etc. complete	M ³	1.50		
3	Cement concrete in foundation with graded stone metal in 1:3:6 with 40mm stone metal all materials, labours, T&P, curing etc. complete	M ³	1.50		

4	Brick work in 1:6 cement mortar for superstructure with K. B. bricks of crushing strength should not be less than 75 kg/sq.cm in superstructure all materials, labours, T&P, curing etc. complete	M ³	14.00		
5	RCC Work:				
a	Cement concrete 1:1.5:3 with graded stone chips (20mm down) excluding shuttering and reinforcement including all good quality approved materials mixed at site as per direction of engineer-in-charge (strength of concrete not less than M20) all materials, labours, T&P, curing etc. complete	M ³	11.00		
b	Reinforcement of tar steel grade Fe415 confirming IS 1786:1979 for reinforced concrete work in all sorts of structure including distributions bars, stirrups, binders etc. including initial straightening and removal of loose rust (if necessary) cutting of requisite length, hooking and bending to correct shape, placing in proper position and biding with 16 gauge black anneled wire at every intersection all materials, labours, T&P, etc. complete	Qntl.	10.00		
c	Hire and labour charges for shuttering and centring and necessary staging using approved stout props and thick hard wood planks of approved thickness with required bracing for concrete slabs, beams columns, lintels, curved or straight including fitting, fixing and striking out after completion of work with plywood shuttering of approved thickness or steel shuttering all materials, labours, T&P, etc. complete	M ²	75.00		
6	Plastering (12mm) thick to wall ceiling with 1:4 cement and sand mortar including rounding off or chamfering corners as directed and racking out joints or roughening of concrete surface including throating, nosing and drip course where necessary to all floor all materials, labours, T&P, curing etc. complete	M ²	180.00		

7	Supply and fitting fixing of flush door (3'-6" x 6'-6") size made of M.S. angle iron frame (40x40x5mm) welded with 03 nos. steel hinges (6" long) and water proof block board 32mm thick shutter fitted with Nickel coated L-drop both side (10" long) and 02 nos. Nickel coated tower bolt (8" long), and 6" long Nickel coated handles both side fitting of door closer and Mortice lock of reputed brand BIS mark & painting with one coat primer and 02 coat enamel paint all materials, labours, T&P, etc. complete	No.	01		
8	Supply and fitting fixing of Openable fully glazed steel Windows (5'-0"x4'-0") size of 75 kg weight with grill and side hung shutter manufactured from rolled steel section with non-friction projecting box type hinges, glazing clips, lugs locking brackets handle. the glass pan should be 4mm thick and fitted and fixed with glazing clip and putty & painting with one coat primer and 02 coat enamel paint including all materials, labours, T&P, etc. complete	No.	01		
9	Supply and fitting fixing of Openable fully glazed steel Windows (3'-0"x4'-0") size of 50 kg weight with grill and side hung shutter manufactured from rolled steel section with non-friction projecting box type hinges, glazing clips, lugs locking brackets handle. the glass pan should be 4mm thick and fitted and fixed with glazing clip and putty & painting with one coat primer and 02 coat enamel paint including all materials, labours, T&P, etc. complete	No.	02		
10	Flooring work:				
	(a) Earth work in filling including watering, ramming i/c all materials, labours, T&P, etc. complete	M ³	10.00		
	(b) Filling with local sand in layers not exceeding 150mm as directed and consolidating same by through saturation with water ramming complete including the cost of supply of sandall materials, labours, T&P, curing etc. complete	M ²	2.00		
	(c) Cement concrete with graded stone metal in 1:3:6 with 40mm stone metal all materials, labours, T&P, curing etc. complete	M ³	2.50		

	(d)Cement concrete 1:2:4 with graded stone chips (20mm down) including all good quality approved materials mixed at site as per direction of engineer-in-charge (strength of concrete not less than M20) all materials, labours, T&P, curing etc. complete	M ³	1.00		
	(e) Supplying, fitting and fixing 1 st quality approved ceramic tiles of (1'x1') size and laid on 25mm thick bed of cement mortar in wall and floor with the existing work, set in 1:2 cement mortar and cement slurry & finishing the joint white cement mixed with matching pigment including all materials, labours, T&P, etc. complete	M ²	29.00		
11	Providing plaster of perish on wall and ceiling or any inside plaster surface including all materials, labours, T&P, etc. complete	M ²	90.00		
12	Applying cement primer one coat over the plaster of perish all materials, labours, T&P, etc. complete	M ²	180.00		
13	Applying two coat washable distemper of approved brand over primer coat on wall and ceiling etc. including sand papering on intermediate coat including putty wherever necessary i/c all materials, labours, T&P, etc. complete	M ²	90.00		
14	Applying two coat cement paint of approved brand over primer coat on wall and ceiling etc. including sand papering on intermediate coat including putty wherever necessary i/c all materials, labours, T&P, etc. complete	M ²	90.00		
15	Provision of cup board with 19mm thick water proof block board and 0.8mm thick sunmica pasted on the one side of the surface of block board with locking arrangement and handle etc. complete materials, labours, carriage etc. complete	Sft.	60.00		
16	Supply and fitting, fixing of PVC rain water pipe (3"dia) and 10'-0" length with GI clamp all material, labour, carriage etc. complete	Nos.	02		
17	Supply of revolving chairs with side arm and high neck approved make with good quality and heavy duty all materials, carriage etc. complete	Nos.	02		

18	Electrification Work:				
a	Supply & Wiring of Bulb Point with PVC Casing & 1.5 sq. mm. single core copper wire (Make: Havells/Finolex/KDK) & supply of CFL Lamp, 14 Watt (Make: Philips/Havells/C&G/Bajaj)	No.	01		
b	Supply & Wiring of Tube Light Point with PVC Casing & 1.5 sq. mm. single core copper wire (Make: Havells/Finolex/KDK) & supply of tube light fitting complete, 40watt, 4ft. (Make: Havells / C&G / Philips / Bajaj)	No.	01		
c	Supply & Wiring of Fan Point with PVC Casing & 1.5 sq. mm. s/c copper wire, Ceiling fan with sweep 1200 mm (Make (Khaitan/Usha/C&G/Havells) and supply & fitting of electronic regulator, step type (Make: Cona/Anchor)	No.	01		
d	Supply & Wiring of 5amp. Socket Point on board	No.	02		
e	Supply & Wiring of 15amp. 5-in-1 Socket Point (Long) with PVC casing for computer	No.	01		
f	Supply & Wiring of Circuit Wiring with 2.5 sq. mm. PVC single core copper wire and point wiring with 1.5 sq. mm. pvc s/c copper wire and running with 0.75 sq.mm. s/c copper flexible wire with PVC casing capping	Lot	01		
g	Supply & erection of 250 watt, HPSV Flood light fitting complete with necessary bend pipe, civil foundation/M.S. clamp and control by 15 amp flash type switch with necessary wiring and PVC casing	No.	02		
h	Supply & Erection of 4 - way distribution box with MCB, 10 Amp Single Pole- 2 Nos. & Double pole 32 amps - 01 No. with sheet steel enclosure	set	01		
i	Supply & Erection of Earthing system with running earth at every point(copper plate earthing)	No.	01		
j	Supply and installation of 1400 VA Inverter make Sukam / Micro tech with battery (make Excide Heavy Duty) & Inverter wiring of all light point and fan point all materials, labour, carriage etc. complete	No.	01		
k	Supply and fitting, fixing of Lightning Arrestor etc. complete	No.	01		

I	Supply and fitting, fixing of Split Air Conditioner (1.50 Ton), 5 star rating with stabilizer (4KVA, voltage range 110 to 300 volt) with suitable starter and make of Blue Star / Voltas /Carrier /LG/Samsung	No.	01		
				Total	
		Rebate if any			
				G. Total	

(Rupees.....
.....) only

SIGNATURE OF THE TENDERER WITH SEAL

Drawing

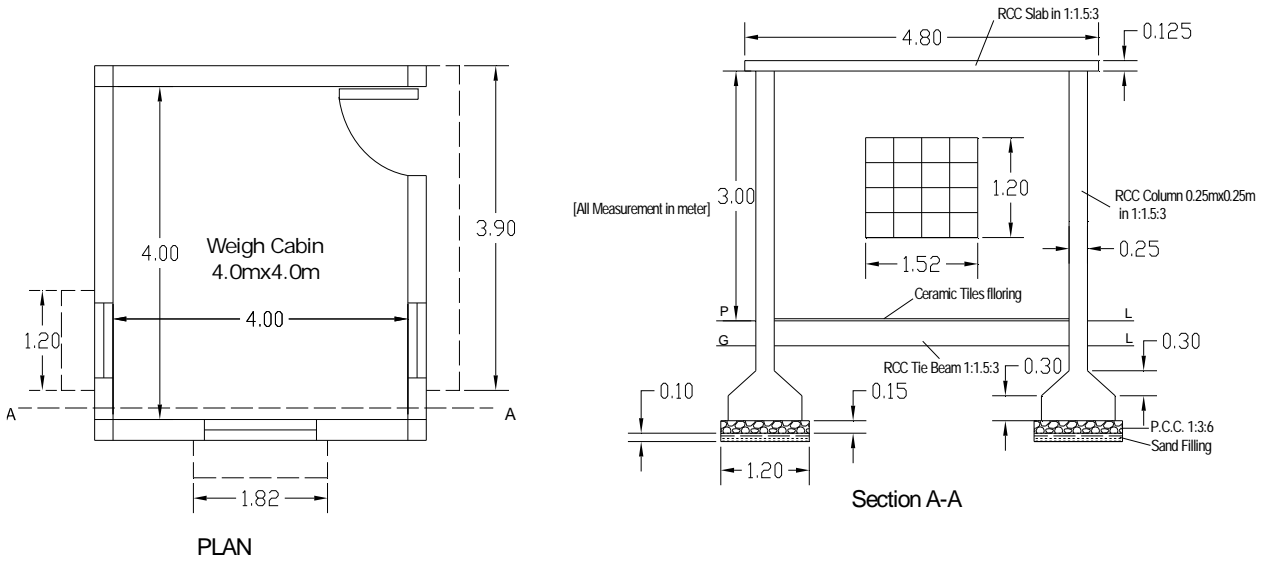

Construction of a weigh cabin (4m x 4m) inner size for installation of inmotion weighbridge at Thakurani Siding.